

INNOVATE

DESIGN

APPLY

[www.ChilledDoor.com](http://www.ChilledDoor.com)

# ChilledDoor®

Rack Cooling System

By  
**motivair**®



[www.ChilledDoor.com](http://www.ChilledDoor.com)



# A whole new cooling experience

The Motivair ChilledDoor® Rack Cooling System targets the critical cooling requirements of today's modern server rack designs. As technology continues to advance, traditional methods of cooling racks such as CRAC/CRAH, containment, hot/cold aisles, and in-row systems have become less appealing as densities increase.

The Motivair ChilledDoor® Rack Cooling System is an active heat exchanger that is mounted directly to the rear panel of any standard server rack. It is capable of removing lower densities up to 75kW per rack. A comprehensive set of environmental variables are constantly monitored to ensure that the ChilledDoor® is actively adjusting to conditions inside the data center. By removing the heat load at its source, Motivair's ChilledDoor® system ensures that all heat being generated by the servers is neutralized before it leaves the cabinet. The result is a "Heat Neutral" white space. Traditional cooling methods are eliminated, the data center cooling footprint is reduced, raised flooring is no longer necessary, and overall data center efficiencies can be increased by up to 90%.

Because the ChilledDoor® works in tandem with the IT hardware fans, the fan's power consumption and the internal operating temperature decreases, resulting in increased energy savings and longevity of the IT equipment.

The Motivair ChilledDoor® system operates above the ambient dew point, which eliminates the possibility of condensation near critical electrical equipment.

## High Density Rack Cooling

- Up to 75kW per rack
- 100% heat removal
- Rack agnostic
- Built in scalability

*"We were in search of a cooling solution for high density computing in a 10,000 sq ft facility. The ChilledDoor's did not take up additional aisle space allowing us to place more equipment on the floor while keeping our cost per kW down."*

– Dan Allen  
VP Facilities & Engineering,  
LightBound®

# Active Rack Cooling. Redefine Your PUE.



## ULTRA EFFICIENT

EC fans dynamically adjust to compensate for changing densities. Capable of removing up to 75kW per rack.

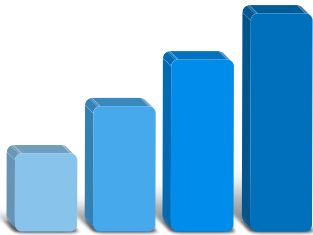

## SCALABLE

Designed for single unit buildup and interchangeable models allowing for future growth.



## RACK AGNOSTIC

Designed for use with any industry standard server rack. Ideal for retrofits or new facilities.

# How it works

Motivair ChilledDoors® can be fitted to the back of any standard or OEM server rack. ChilledDoors® have been designed to remove heat generated by the IT equipment directly at its source, preventing hot air from entering the white space. This ensures optimal thermal and energy performance.

Room air is pulled into the cabinet via the ChilledDoor's® EC fans. The room air picks up heat as it passes through the servers and then enters the ChilledDoor's® high efficiency heat exchanger. The heat is transferred to the coolant inside the heat exchanger and sent out to the chilled water source (see exploded view example). The ChilledDoor® then exhausts cool air back to the room at a predetermined set point. The ChilledDoor® monitors the server air temperature or pressure, ambient room temperature, entering water temperature, and leaving air temperature, allowing it to actively adjust to changes at the rack level. By doing this it creates a "heat neutral" environment requiring only humidity control.

Motivair ChilledDoors® are available with 2-5 fans providing maximum scalability and flexibility for future growth. The ChilledDoor® comes in seven different models including the M4, M8, M12, M12-SP, M14, G2 and M16. Motivair has the solution to meet all of your rack cooling needs today and in the future.

"Active" ChilledDoors® can be leveraged for greenfield or retrofit applications, including hot spots or efficiency upgrades. They are designed for high-efficiency cooling of complete data centers in an every-rack or every-other-rack configuration (please consult Motivair for every-other-rack designs). Because the ChilledDoor® is able to control an entire room, the user no longer has a need for traditional supplemental cooling solutions.

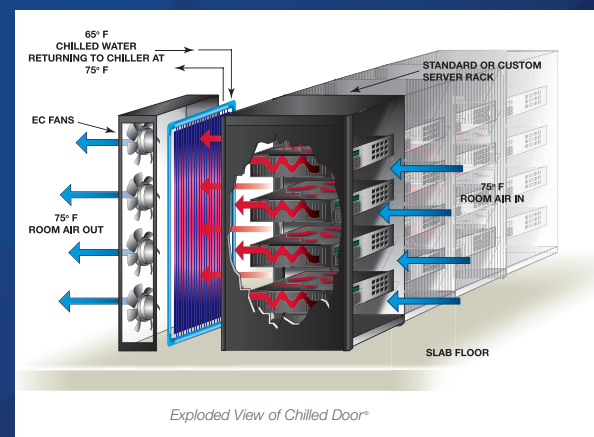

# Features



**PLC Control System**  
Simple navigation, adjustable set points and alarms provide you with individual ChilledDoor® setup, control, and monitoring.



**Low Profile Footprint**  
Maximum cooling, compact design.



**Hot Swappable Fans**  
Allows for quick service replacement with no downtime.

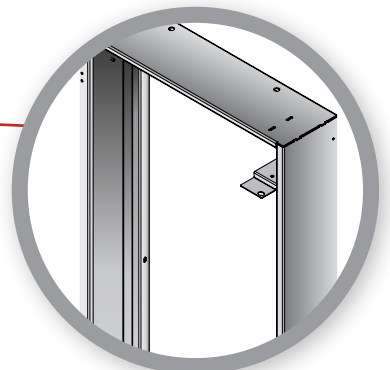

**Interface Frame Mounting System**  
Seamless integration with your server rack.

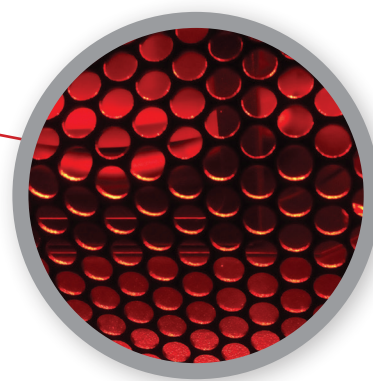

**LED Status Indicator**  
Provides your data center team with visual ChilledDoor® status.

**TECHNICAL SPECIFICATIONS AND FEATURES**

	<b>M4</b>	<b>M8</b>	<b>M12</b>	<b>M12-SP</b>	<b>M14</b>	<b>G2</b>	<b>M16</b>
Available Height (Range)	42U - 60U	42U - 60U	42U - 60U	42U - 60U	42U - 60U	48U - 60U	48U - 60U
Available Width (Range) (Outside Dimensions)	600-800MM (23" - 31")	600-800MM (23" - 31")	600-800MM (23" - 31")	600-800MM (23" - 31")	600-800MM (23" - 31")	762-800MM (30" - 31")	762-800MM (30" - 31")
Depth (Inches)	13.3	13.3	13.3	13.3	15.7	16.8	17.5
Nominal Cooling Capacity (kW)*	12	30	45	55	65	70	75
GPM (Range)	0 - 23	0 - 23	0 - 23	0 - 23	0 - 23	0 - 23	0 - 23
Max Watts	840	840	840	840	2500	840	2500
Fan Quantity	2 - 5	5	5	5	5	5	5
Power Supply:							
230V/1PH/50-60HZ	S	S	S	S	S	S	S
208V/1PH/60HZ	S	S	S	S	S	S	S
277V/1PH/50-60HZ	O	O	O	O	O		O

\*Calculated at 35% RH and 75F Room Temp; Supply Temperature Range 55F - 65F water; 100% water

**FEATURES**

PLC with local HMI screen	S	S	S	S	S	S	S
Variable "EC" fans	S	S	S	S	S	S	S
Dual power supply (A/B)	O	O	O	O	O	O	O
Network remote monitoring/control	O	O	O	O	O	O	O
Individual fan fail sensing	S	S	S	S	S	S	S
Local visual/audible alarm	S	S	S	S	S	S	S
Leak Prevention System/Detection	S	S	S	S	S	S	S
Modulating Two-Way Valve	S	S	S	S	S	S	S
Common Alarm Relay	S	S	S	S	S	S	S
Top or Bottom Connections	S	S	S	S	S	S	S
Differential Pressure Control	O	O	O	O	O	O	O
100% Failover Mode	S	S	S	S	S	S	S
Overcool Mode	S	S	S	S	S	S	S
C14 Plug Type	S	S	S	S	S	S	S
Alternative Plug Types available	O	O	O	O	O	O	O
Rack Access (Key)	S	S	S	S	S	S	S
Rack Access (Code)	O	O	O	O	O	O	O

**FACTORY CERTIFIED SERVICES**

Installation	O	O	O	O	O	O	O
Start-Up	O	O	O	O	O	O	O
Commissioning Support	O	O	O	O	O	O	O
Warranty (Parts)	O	O	O	O	O	O	O
Preventative Maintenance	O	O	O	O	O	O	O

Open19 and OCP compliant.  
S=Standard; O=Optional  
ETL, CSA, CE Certified  
Manufactured in the USA

# OUR BUSINESS IS COOLING YOURS™



## Coolant Distribution Unit (CDU)

A CDU provides the ability to deploy higher density, load diverse IT equipment in a smaller footprint while at the same time improving a facility's overall efficiency (PUE) and life expectancy. The CDU provides 100% sensible cooling up to 1.25MW, depending on the model. For use with the ChilledDoor® or other IT cooling systems.



## In-Rack Coolant Distribution Unit (CDU)

Motivair's latest MCDU-4U provides all the benefits of a CDU, but can be mounted within a standard 19" rack enclosure. With a cooling capacity of 80kW (with ChilledDoor®) and 105kW (with other IT computer cooling systems), the MCDU-4U is ideal for smaller IT deployments, areas with space constraints, or to address hot spots in air-cooled data centers.

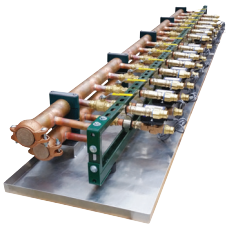

## Manifold Systems

A manifold provides a common connection point between the ChilledDoors® and the supply and return cooling infrastructure system or CDU. It is typically installed under the raised floor, but can be hung overhead for installations without raised floors. Each manifold is preconfigured with quick connect fittings for use with Motivair® hoses and individual 2-way valves for each door. Available options include 6, 12 and 16 port assemblies.



## Motivair Free-Cooling Chillers

The Motivair® Free-Cooling chillers were created to serve year-round mission critical cooling loads for data centers. Generations of Free Cooling chiller software design and implementation allow for optimal water side economizing hours, rapid restart after power failure, and tight temperature control during extreme year-round weather patterns.



## Service & Maintenance Program

Motivair® provides customer-focused service and support for your mission critical equipment. We offer site surveys, installation services, commissioning services, service agreements, and extended warranties on parts.

**ChilledDoor®**  
Rack Cooling System

By  
**motivair®**

85 Woodridge Drive  
Amherst, NY 14228

Tel: 716-691-9222

Fax: 716-691-9229

[www.motivaircorp.com](http://www.motivaircorp.com)